





HD76 4WD



SMART 60



SMART 60



HD96 4wd



HD100 4wd



WORLD'S BEST Components
sourced from world's leading manufacturers.



60 / 76 / 96 HP
Proven Kirloskar Engine
100 HP Perkin's engine



60 / 76 / 96 HP
Carraro (Italy) Transmission
100 Hp ZF (German) Transmission



Hydro Control
(Italy) Valve



Danfoss Brake
(Denmark)



Cassapa
(Italy) pump



World Famous
Carraro (Italy) Axle



AKG (German)
Radiator Cooler

EXTRAORDINARY RELIABILITY in demanding
Heavy duty abusive applications, delivering consistent high performance .



Steel - Sliding/Swivel King Post
No Breakage



Heavy Duty, Durable Pins &
Bushes Ensuring Longer Life



Auto Greasing System
(Optional)



BULL

HD 76

BULL

HEAVY DUTY

HD 76

BULL

SALIENT FEATURES

All machines come with advanced features which are the pride for all owners while surpassing others on Performance, Productivity and Reliability.



Heavy Weight Champion
(550 Kg More Weight)

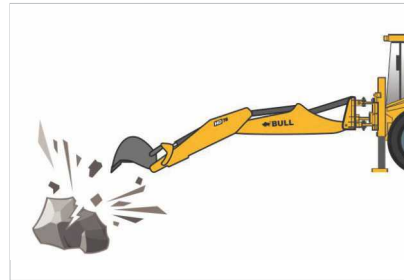

More Bucket Breakout Force
& Backhoe Bucket Capacity



Powder Coating : Scratch
Resistant Painting



10% more traction



Better Weight Distribution
Effy Power Drive System



The Tallest Dumping Backhoe
Loader in the World

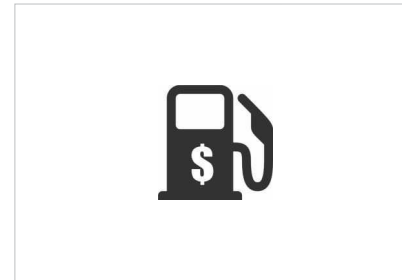

Most fuel efficient backhoe
in the world in its class*

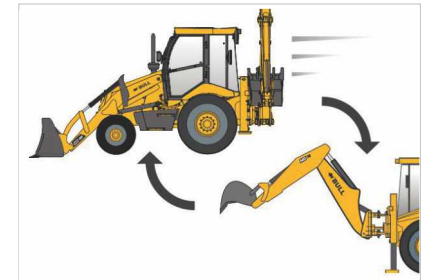

Effy power selector switch
Wheel drive / backhoe



EASY TO MAINTAIN AT LOW COST

An Operator friendly machine that facilitates and alerts the operator for regular maintenance.



Engine high temperature
Warning Alarm



Integrated oil filter with
Breather



Front Opening Bonnet



Single layer Radiator/
Cooler: Easy to clean

WORLD CLASS CABIN COMFORT

Incorporated with features for the practical needs of the operator for uninterrupted fatigue free working for longer hours



Joystick with Selector Switch



Tiltable Steering



60/ 76/ 96 HP
Forward reverse Switch



A/C Option



MULTIPLE BUCKET OPTIONS

Rock Breaker

Trench Breaker

Fork Lift

Booster Bucket
(12.98 ft Dump Height)

Bale Grabber

Grabbing Fork

Brick Grabber

Road Roller Compactor

Sugarcane Grabber

Detachable Dozerblade
6 in 1 Bucket

With Quick Hitch

Optional Quick Hitch



6 in 1 Bucket



Booster Bucket



Backhoe



Grabbing fork Booster Bucket



Concrete Mixer



Road Roller



Grabbing fork



Sugar Cane Grabber



Backhoe Unloading Inside Truck



SMART 60

HD 76

HD 96

HD 100

ENGINE	Kirloskar 4R 810T, TC EURO III, Diesel Engine Gross Power : 44.8 kW (60HP) @ 2400 RPM Gross Torque : 215 Nm@1600 RPM	Kirloskar 4R 1040, TC EURO III A, Diesel Engine Gross Power : 56.7 kW (76HP) @ 2200 RPM Max Torque : 300 Nm@1500 RPM	Kirloskar 4R 1040, TA2 EURO III A, Diesel Engine Gross Power: 71.6 kW (96 HP) @ 2200 RPM Max Torque: 377 Nm@1400 RPM	PERKINS 1104D-44TA, EU NRMM 97 / 68 / EC EURO III A Gross Power: 74.5 kW (100 HP) @ 2200 RPM Max Torque: 410 Nm@1400RPM
TRANSMISSION	CARRARO synchro-shuttle transmission with integral torque converter	CARRARO synchro-shuttle transmission with integral torque converter	CARRARO synchro-shuttle transmission with integral torque converter	ZF Power Shift transmission with integral torque converter
STEERING	Power Steering	Power Steering	Power Steering	Power Steering
ELECTRICALS	12V Battery System (90 Ah)	12V Battery System (130 Ah)	12V Battery System (180 Ah)	12V Battery System (180 Ah)
TYRES	FRONT 2 WD - 9 x 16 - 16 PR 4 WD - 12.5/80 x 18 - 12 PR REAR Industrial - 14 x 24 - 16 PR Heavy Duty - 14 x 24 - 20 PR	FRONT 2 WD - 9 x 16 - 16 PR 4 WD - 12.5/80 x 18 - 12 PR REAR Industrial - 16.9 x 28 - 12 PR Heavy Duty - 14 x 25 - 20 PR	FRONT 2 WD - 9 x 16 - 16 PR 4 WD - 12.5/80 x 18 - 12 PR REAR Industrial - 16.9 x 28 - 12 PR Heavy Duty - 14 x 25 - 20 PR	FRONT 2 WD - 9 x 16 - 16 PR 4 WD - 12.5/80 x 18 - 12 PR REAR Industrial - 16.9 x 28 - 12 PR Heavy Duty - 14 x 25 - 20 PR
SPEED	Forward max 30 Km/Hr Reverse max 9.3 Km/Hr	Forward max 40Km/Hr Reverse max 9.3 Km/Hr	Forward max 40Km/Hr Reverse max 9.3 Km/Hr	Forward max 37 Km/Hr Reverse max 22 Km/Hr
HYDRAULICS	Smart Technology hydraulics : 2900 psi (200 bar) Pump O/P: 110 LPM@2400 RPM	Smart Technology hydraulics : 3335 psi (230 bar) Pump O/P: 113 LPM@2200 RPM	Smart Technology hydraulics : 3335 psi (230 bar) Pump O/P: 134 LPM@ 2200 RPM	Smart Technology hydraulics : 3335 psi (230 bar) Pump O/P: 145 LPM@2200 RPM
WEIGHT	6720 Kgs with Standard GP Bucket option	7850 Kgs with Standard GP Bucket option	8150 Kgs with Standard GP Bucket option	8200 Kgs with Standard GP Bucket option
OPTIONS	Ditch Cleaning Bucket Square Hole Bucket Rock breaker Ripper tooth Trench bucket Taper Ditching bucket Multipurpose 6 in 1 bucket Telescopic Dipper AC Cabin Loader Booster bucket with 12' 98" dump height			

EXCAVATOR PERFORMANCE		60 HP	76 HP		96 HP		100 HP	
			Retraction STD	Telescopic Dipper (option)	Retraction STD	Telescopic Dipper (option)	Retraction STD	Telescopic Dipper (option)
A	Standard GP Bucket Capacity	0.23 cu.m	0.27 cu.m		0.27 cu.m		0.27 cu.m	
A	Maximum DIG depth	3.56 m	4.60 m	5.59 m	4.60 m	5.59 m	4.60 m	5.59 m
B	Reach Ground Level to Rear wheel center	6.32 m	6.80 m	7.91 m	6.80 m	7.91 m	6.80 m	7.91 m
C	Reach at Ground level to slew center	5.10 m	5.50 m	6.60 m	5.50 m	6.60 m	5.50 m	6.60 m
D	Reach at full height to slew center	2 m	2.85 m	3.56 m	2.85 m	3.56 m	2.85 m	3.56 m
F	Maximum working height	5.40 m	5.92 m	6.77 m	5.92 m	6.77 m	5.92 m	6.77 m
G	Maximum Load over Height	3.74 m	4.14 m	5.02 m	4.14 m	5.02 m	4.14 m	5.02 m
H	Bucket Rotation power	200°	188°		188°		188°	
	Bucket Tear out force	5610Kgf	6072 Kgf		6072 Kgf		6392 Kgf	
	Dipper Tear out force	2200 Kgf	3150 Kgf		3150 Kgf		3316 Kgf	

LOADER PERFORMANCE		60HP	76HP	96HP	100HP
	Standard GP Bucket Capacity	1 cu.m	1.1 cu.m	1.1 cu.m	1.2 cu.m
II	Dump Height	2.96 m	2.96 m	2.96 m	2.96 m
J	Load Over Height	3.39 m	3.39 m	3.39 m	3.39 m
K	Pin Height	3.61 m	3.61 m	3.61 m	3.61 m
L	Pin Forward Reach	0.42 m	0.42 m	0.42 m	0.42 m
M	Reach at Ground	1.47 m	1.47 m	1.47 m	1.47 m
N	Reach at full height	1.28 m	1.28 m	1.28 m	1.28 m
O	Reach at full Height bkt Dumping	0.89 m	0.89 m	0.89 m	0.89 m
P	Below ground level DIG Depth	0.1 m	0.1 m	0.1 m	0.1 m
Q	Roll back at Ground	49°	49°	49°	49°
R	Dump Angle	45°	45°	45°	45°
	Bucket Break-out Force	7178 Kgf	8183 Kgf	8183 Kgf	8793 Kgf
	Loader Arm Break-out Force	4606 Kgf	5251 Kgf	5251 Kgf	5642 Kgf
	Pay Load	1560 Kgf	1800 Kgf	1800 Kgf	2000 Kgf

STATIC DIMENSIONS		60 HP	76 HP	96 HP	100 HP
AA	Over all length	5.85 m	6.04 m	6.04 m	6.04 m
BB	Wheelbase	2.08 m	2.22 m	2.22 m	2.22 m
CC	King post travel	0.99 m	1.03 m	1.03 m	1.03 m
DD	Minimum ground clearance	0.42 m	0.48 m	0.48 m	0.48 m
EE	Slew ground clearance	0.6 m	0.65 m	0.65 m	0.65 m
FF	Height to top of bonnet	1.99 m	1.99 m	1.99 m	1.99 m
GG	height to top of cabin	3.00 m	3.00 m	3.00 m	3.00 m
HH	Over all height	3.46 m	3.71 m	3.71 m	3.71 m
JJ	Track width - rear	1.65 m	1.70 m	1.70 m	1.70 m
KK	Track width - front	1.79 m	1.93 m	1.93 m	1.93 m
LL	Width over bucket	2.2 m	2.35 m	2.35 m	2.35 m
MM	Side reach to center line of machine	4.63 m	6.08 m	6.08 m	6.08 m

DIMENSIONS

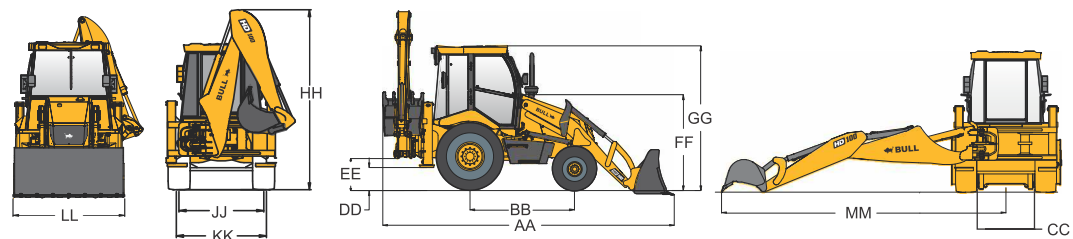
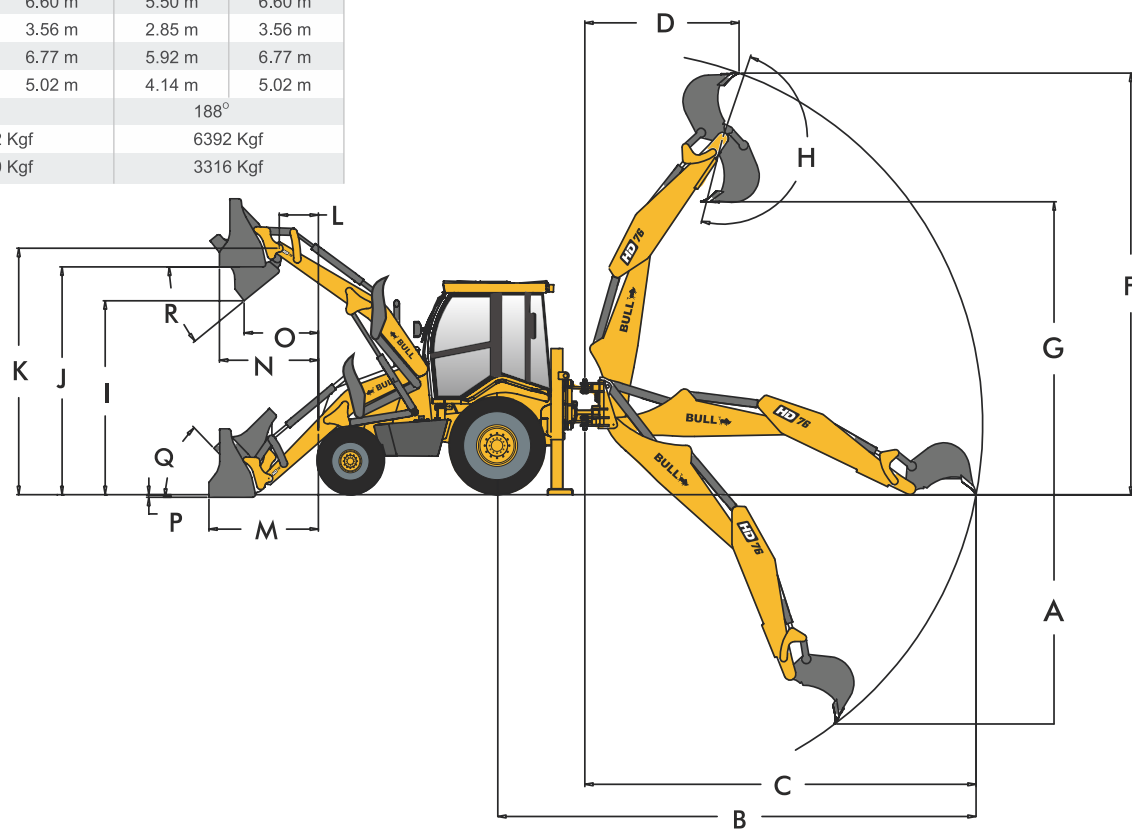



WORLD CLASS PLANTS

UNIT 1



WORLD CLASS PLANTS

UNIT 2



WORLD CLASS PRODUCTION LINE



- BULL has two world-class manufacturing plants with state of the art manufacturing facilities.
- The construction equipment plant has a capacity of 3000 vehicles per annum.
- Worldwide sales and service network of 600 plus dealers and 7 branch offices across India.
- Largest selling tractor attachment manufacturer in India.
- More than 30,000 **BULL** products are running across the globe.
- **BULL** has been Recognised by the Ministry of Science and Technology as an in-house R&D company.
- **BULL** runs on world class systems including SAP.
- Backed by an extensive sales and service network with more than 100 resident service engineers across the world.
- At **BULL** Innovation is a way of life where quality is first priority.
- **BULL** belongs to 54 year old AV group which has diversified companies employing more than 2000 people.
- **BULL** is innovation driven organization with strong R&D team and holds many patents to its credit.

BULL TEMPLE

BULL temple represents the foundation, structure and the core values of the company.



BULL PHILOSOPHY

BULL philosophy reflects the culture of BULL MACHINES. The same is the mantra and ritual for every bull employee and we are bound by it.

AT BULL - **LOW AIM IS A CRIME.**
AT BULL - **I BELIEVE IN MYSELF.**
AT BULL - **QUALITY IS THE FIRST PRIORITY AND MY RESPONSIBILITY.**
AT BULL - **I BELIEVE IN INNOVATIONS.**
AT BULL - **I BELIEVE THAT EVERY PROBLEM HAS A SOLUTION.**
AT BULL - **I BELIEVE IN GOD AND FOR EVERYTHING ELSE I DEMAND DATA.**
AT BULL - **I AM HUNGRY FOR KNOWLEDGE**
AT BULL - **I BELIEVE THAT KNOWLEDGE IS HIDING IN PROBLEMS**
AT BULL - **I ENJOY CHALLENGING AND SOLVING THE PROBLEMS.**
AT BULL - **I BELIEVE IN SIMPLIFYING THE COMPLEXITIES.**
AT BULL - **I BREAK BARRIERS AND RULES TO ATTAIN OBJECTIVES.**
AT BULL - **I AM CUSTOMER CENTRIC AND OBJECTIVE DRIVEN.**
AT BULL - **I PLAN AND EXECUTE WITH SENSE OF URGENCY.**
AT BULL - **I TAKE RESPONSIBILITY BECAUSE I AM A LEADER.**
AT BULL - **I AM READY TO CHANGE ANYTHING, EXCEPT FOR OUR HONESTY AND INTEGRITY.**
AT BULL - **I AM SELF DISCIPLINED AND CONSISTENT.**
AT BULL - **I TRUST MY TEAM AND BELIEVE IN TEAM WORK**
AT BULL - **I AM TIME CONSCIOUS AND COST CONSCIOUS.**
AT BULL - **I BELIEVE THAT I CAN IMPACT THE WORLD.**
AT BULL - **I BELIEVE IN RCA - CAPA & BMS WHICH ARE OUR WAY OF LIFE.**
AT BULL - **UNDYING POSITIVE ENERGY IS WHAT I BREATHE.**
AT BULL - **THE WORD CAN'T IS REMOVED FROM OUR VOCABULARY.**

Our other range of TA products



India's No.1
Tractor Attachments



SINCE 1962

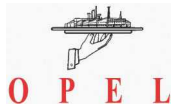

SANDFITS



BULL MACHINES PVT.LTD

Trichy Road, Coimbatore. INDIA

sales@bullmachine.com | exports@bullmachine.com